



**2-1/2 in. Carbon Steel, Cast Gate Valve.
 Class 300 Rating, Flanged Connection 8
 (CR13/HF) Trim, Outside Stem & Yoke
 (OSY)**

<u>Item No.</u>	M100417	<u>UOM</u>	EA
-----------------	---------	------------	----

[View Product Online to Request Quote](#)

Specifications

Type	Gate Valve
Item Remarks	Outside Stem & Yoke (OSY)
Size	2-1/2 in.
Material	Steel
Material Grade	Carbon Steel, Cast
Trim	TRIM 8 (CR13/HF)
Pressure Class	Class 300
Connection	Flanged
Specification	ANSI B16.5
Market	Commercial

Product URL: <https://torksystems.com/M100417>

OVC# CS300GT

Class 300 Carbon Steel Gate Valve

Features

- Face to face dimensions: ASME B16.10
- Flange end dimensions: ASME B16.5
- Test: API 598
- Design: API 600

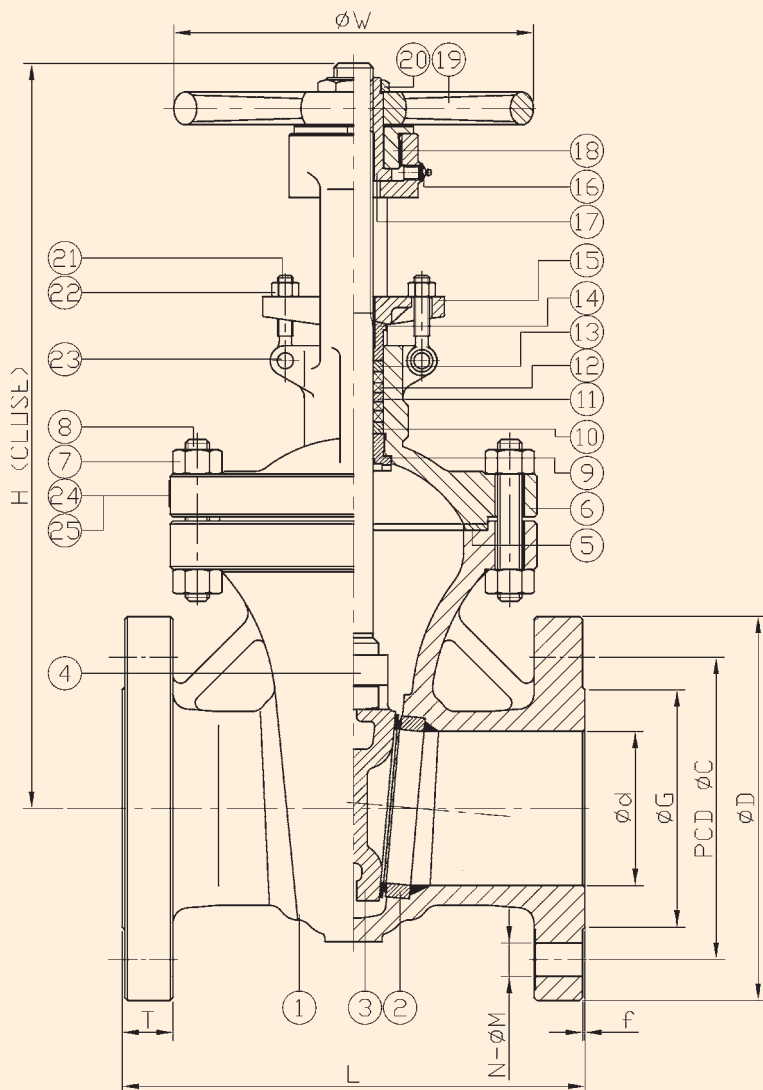

NO.	DESCRIPTION	MATERIAL
1	BODY	ASTM A216-WCB
2	SEAT RING	ASTM A105+STL#6
3	WEDGE	ASTM A216-WCB+Cr13
4	STEM	ASTM A182-F6a
5	GASKET	SS 304 + GRAPHITE
6	BONNET	ASTM A216-WCB
7	NUT	ASTM A194-2H
8	STUD	ASTM A193-B7
9	BACK SEAT	ASTM A276-410
10	PACKING A	GRAPHITE
11	SPACER RING	ASTM A276-410
12	PACKING B	GRAPHITE
13	PACKING C	GRAPHITE
14	GLAND	ASTM A276-410
15	GLAND FLANGE	ASTM A216-WCB
16	GREASE FITTING	CARBON STEEL
17	STEM BUSHING	ASTM A439 D-2
18	RETAINING NUT	ASTM A29-1025
19	HANDWHEEL	DUCTILE IRON
20	NUT	ASTM A29-1025
21	EYE BOLT	ASTM A193-B7
22	NUT	ASTM A194-2H
23	PIN	ASTM A29-1025
24	NAMEPLATE	SS 304
25	RIVET	SS 304

NPS	d	G	C	D	L	H	W	T	f	M	N	Weight (lb)
2"	2	3.62	5	6.5	8.5	13.78	7.87	0.91	0.06	0.75	8	66.1
2-1/2"	2.5	4.13	5.87	7.48	9.5	15.55	7.87	1.02	0.06	0.87	8	92.6
3"	3	5	6.63	8.27	11.125	16.97	9.84	1.14	0.06	0.87	8	121.3
4"	4	6.18	7.87	10	12	19.65	9.84	1.26	0.06	0.87	8	183
5"	5	7.32	9.25	10.98	15	22.2	11.81	1.38	0.06	0.87	8	238.1
6"	6	8.5	10.63	12.52	15.875	25.47	13.78	1.46	0.06	0.87	12	302
8"	8	10.63	12.99	15	16.5	29.8	15.75	1.65	0.06	0.98	12	529.1
10"	10	12.76	15.26	17.52	18	36.5	17.72	1.89	0.06	1.14	16	734.1
12"	12	15	17.76	20.51	19.75	42.13	19.69	2.01	0.06	1.26	16	1181.7

TOLL FREE (877) 423-2660 • (513) 752-5600 • FAX (513) 752-8267
 EMAIL sales@ohiovalve.com • WEB www.ohiovalve.com