



**1/2 in. Carbon Steel, Forged Gate Valve.
 Class 800 Rating, Socket weld
 Connection. ANSI B1634**

<u>Item No.</u>	M102897	<u>UOM</u>	EA
-----------------	---------	------------	----

[View Product Online to Request Quote](#)

Specifications

Type	Gate Valve
Size	1/2 in.
Material	Steel
Material Grade	Carbon Steel, Forged
Pressure Class	Class 800
Connection	Socket weld
Specification	ANSI B16.34
Market	Commercial

Product URL: <https://torksystems.com/M102897>

OVC# GA800SW/TE

Socket Weld End & Threaded End Forged Steel Gate Valve

Features

- Basic design: API 602
- Test: API 598
- Socket weld dimensions: ASME B16.11
- Screw end dimensions: ASME B1.20.1 (NPT)

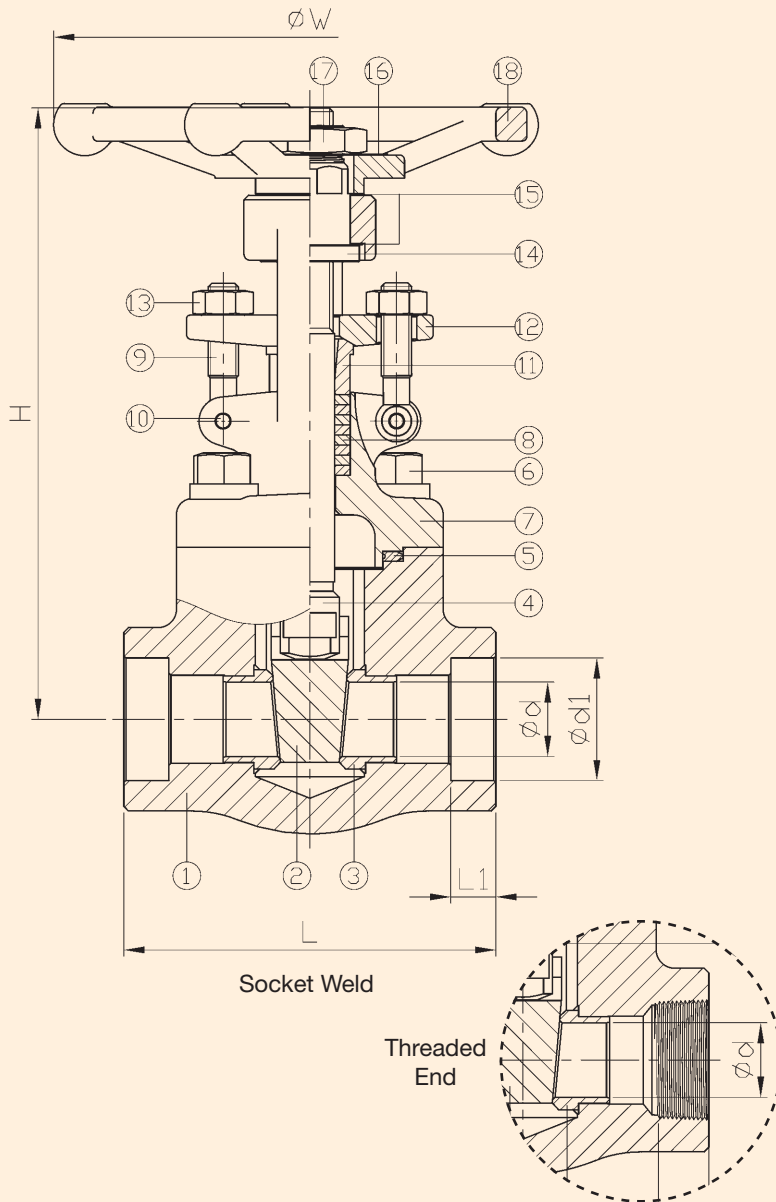

NO.	DESCRIPTION	MATERIAL
1	BODY	ASTM A105
2	WEDGE	ASTM A276-420
3	SEAT	ASTM A276-410 + STELLITE
4	STEM	ASTM A276-410
5	GASKET	304 + GRAPHITE
6	BOLT	ASTM A193-B7
7	BONNET	ASTM A105
8	PACKING	GRAPHITE
9	EYE BOLT	ASTM A193-B7
10	PIN	ASTM A276-304
11	GLAND	ASTM A276-420
12	GLAND FLANGE	ASTM A216-WCB
13	NUT	ASTM A194-2H
14	STEM NUT	ASTM A276-410
15	WASHER	ASTM A276-410
16	NAMEPLATE	ALUMINUM
17	HANDWHEEL NUT	ASTM A108-1020
18	HANDWHEEL	ASTM A197

NPS	d	d1	L	L1	H OPEN	H CLOSE	W	Weight (lb)
1/4"	0.30	0.56	3.11	0.39	6.18	5.59	3.94	4.6
3/8"	0.37	0.69	3.11	0.39	6.18	5.59	3.94	4.6
1/2"	0.51	0.86	3.11	0.39	6.18	5.59	3.94	4.4
3/4"	0.51	1.07	3.62	0.51	6.18	5.59	3.94	4.9
1"	0.71	1.33	4.37	0.51	7.28	6.50	4.72	7.7
1-1/4"	0.94	1.68	4.72	0.51	8.90	7.87	6.30	11.7
1-1/2"	1.14	1.92	4.72	0.51	9.49	8.23	6.30	13.4
2"	1.44	2.41	5.51	0.63	10.59	9.02	8.66	21.1